

# Lecture 17: Radial Wavefunction and Orbital Levels of the Hydrogen Atom

The material in this lecture covers the following in Atkins.

The structure and Spectra of Hydrogenic Atoms

Section 13.1 The structure of hydrogenic atoms

(b) The radial solution

13.2 Atomic orbitals and their energies

(a) The energy levels

(b) Ionization Energies

Lecture on-line

Hydrogen energy levels and radial wavefunction (PDF Format)

Hydrogen energy levels and radial wavefunction (PowerPoint)

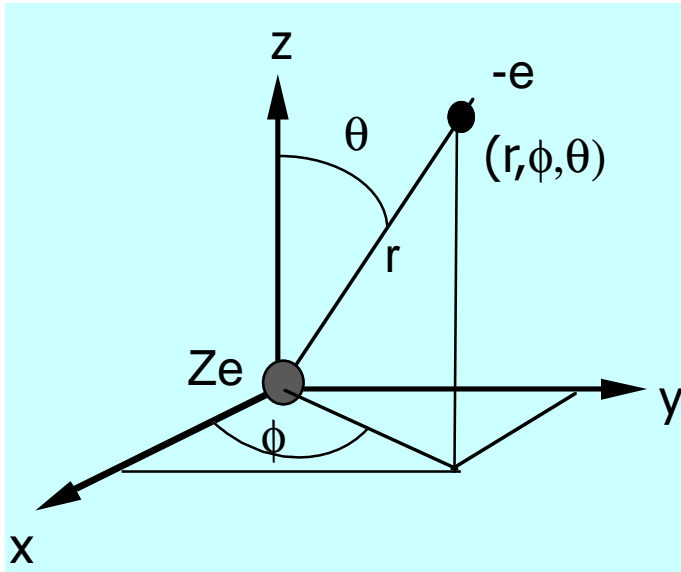

## Hydrogen Levels

**Review : Quantum numbers of the hydrogenic atom**

**The wavefunction of the hydrogenic atom depends on three quantum numbers**

$$\psi(r, \phi, \theta) = R_{nl}(r)Y_{l,m}(\phi, \theta)$$

**The principle quantum number :  $n = 1, 2, 3, 4, \dots$**

**Angular momentum quantum number :  $l = 0, 1, 2, 3, \dots, n - 1$**

**Magnetic quantum number :  $m_l = l, l - 1, l - 2, \dots, -l$**

$$E = - \frac{Z^2 \mu e^4}{32\pi^2 \epsilon_0^2 \hbar^2 n^2}$$

## Hydrogen Levels

## Review : Quantum numbers of the hydrogenic atom

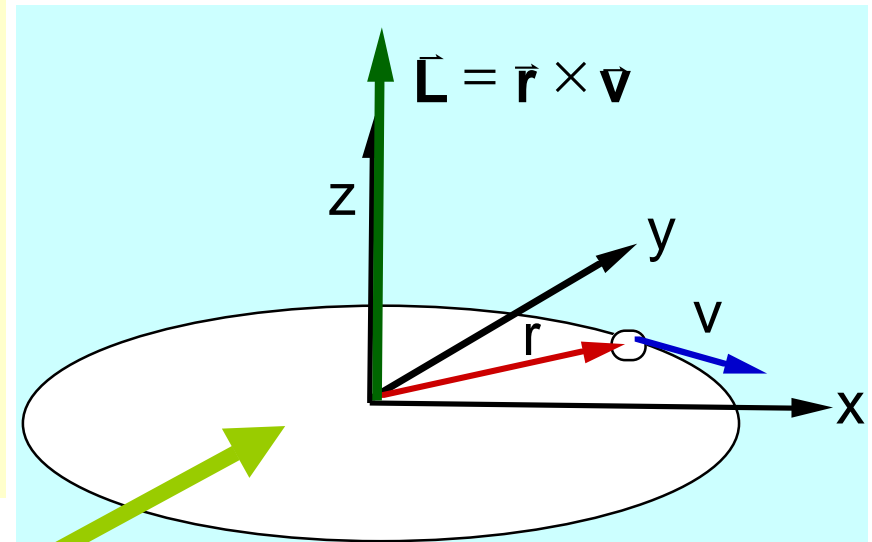
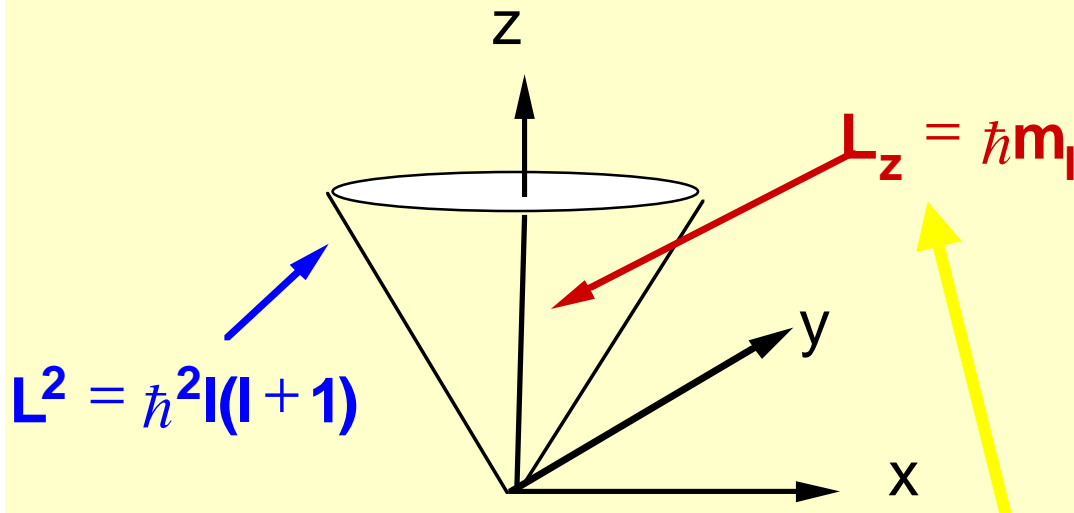

Angular momentum quantum number :  $l = 0, 1, 2, 3, \dots, n-1$  is related to the length  $L$  of the angular momentum of the electron as it moves around nucleus

Magnetic quantum number :  $m_l = l, l-1, l-2, \dots, -l$  is related to the length of the projection of  $\vec{L}$  on to an arbitrary vector ( $\vec{e}_z$ ).

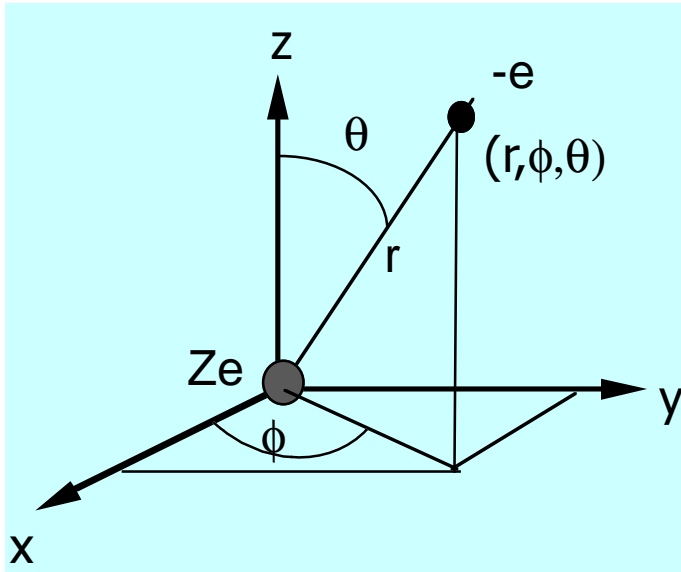

## gen Levels

**Review : Radial wavefunction  $R_{nl}(r)$  of the hydrogenic atom**

**The wavefunction of the hydrogenic atom is given by :**

$$\psi(r, \phi, \theta) = R(r)_{nl} Y_{l,m}(\phi, \theta)$$

**With the radial part given as**

$$R_{nl}(r) = N_{nl} \left( \frac{\rho}{n} \right)^l L_{n,l}(r) e^{-\rho/2n}$$

**Normalization**

**Polynomial**

**Exponential**

## Hydrogen Levels

$n = 1 ; l = 0$

Review : Radial wavefunction  $R_{nl}(r)$  of the hydrogenic atom

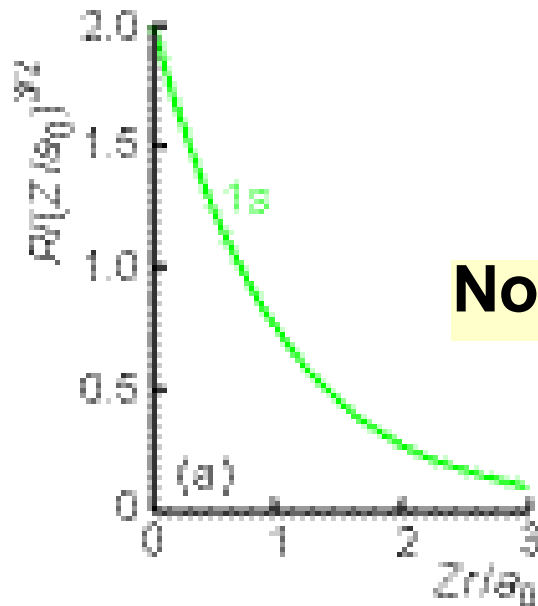

No nodes.  $R_{1,0}(r)$  everywhere positive

$$R_{10}(0) \neq 0$$

$$\rho = \frac{2Zr}{a_0} \quad \text{and} \quad a_0 = \frac{4\pi\epsilon_0\hbar^2}{m_e e^2}$$

$$R_{1,0}(r) = 2 \left( \frac{Z}{a_0} \right)^{3/2} e^{-\rho/2}$$

# Hydrogen Levels

## Review : Radial wavefunction $R_{nl}(r)$ of the hydrogenic atom

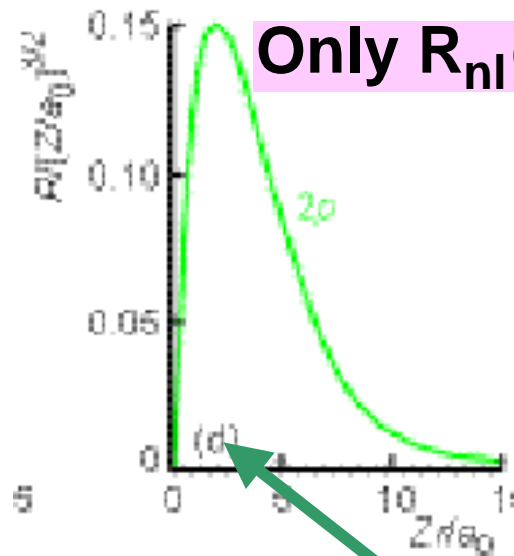
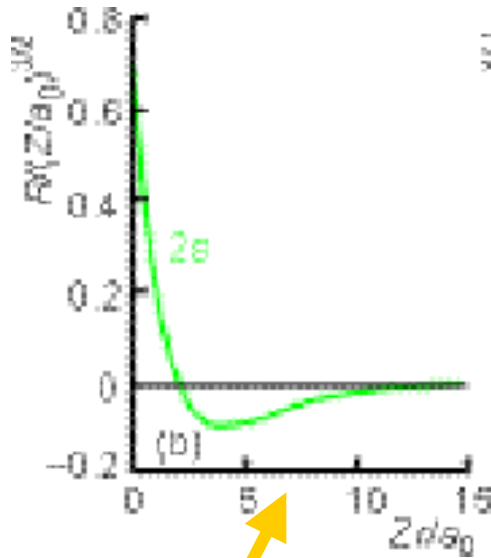

Only  $R_{nl}(r)$  with  $l = 0$  has  $R_{nl}(0) \neq 0$

$R_{2,0}(r)$  : one node  
 $R_{2,1}(r)$  : zero nodes

$$\rho = \frac{2Zr}{a_0} \quad \text{and} \quad a_0 = \frac{4\pi\epsilon_0\hbar^2}{m_e e^2}$$

$$R_{20}(r) = \frac{1}{2\sqrt{2}} \left(\frac{Z}{a_0}\right)^{3/2} \left(2 - \frac{1}{2}\rho\right) e^{-\rho/4} \quad R_{2,1}(r) = \frac{1}{4\sqrt{6}} \left(\frac{Z}{a_0}\right)^{3/2} \rho e^{-\rho/4}$$

# Hydrogen Levels

# Review : Radial wavefunction $R_{nl}(r)$ of the hydrogenic atom

$R_{30}(r)$  : 2 nodes

$R_{31}(r)$  : 1 node

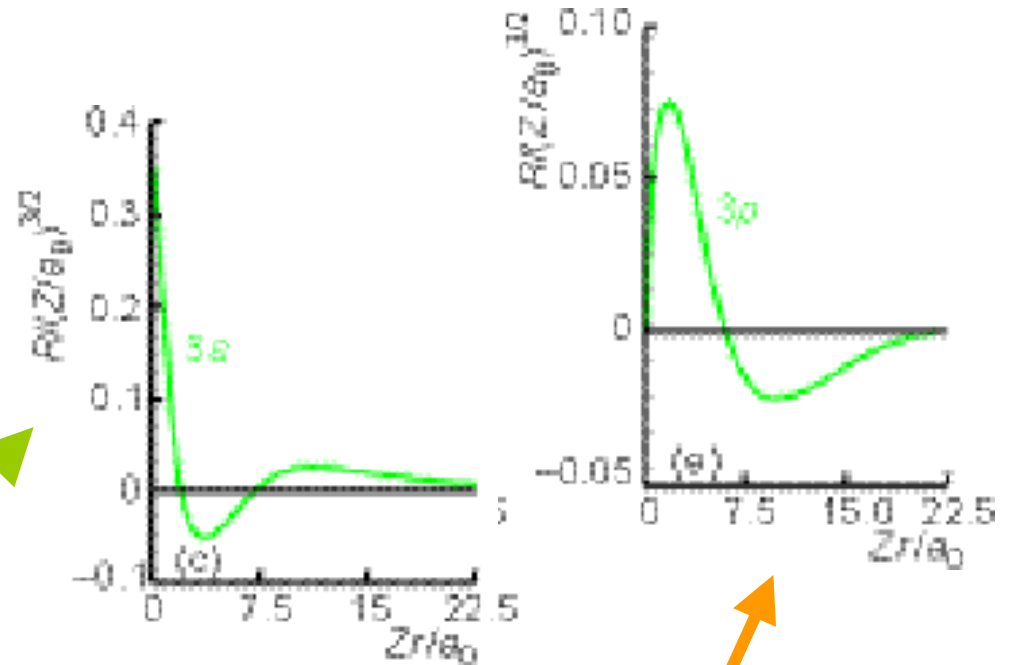

$$R_{30}(r) = \frac{1}{9\sqrt{3}} \left( \frac{Z}{a_0} \right)^{3/2} \left( 6 - 2\rho + \frac{1}{9}\rho^2 \right) e^{-\rho/6}$$

$$R_{31}(r) = \frac{1}{27\sqrt{6}} \left( \frac{Z}{a_0} \right)^{3/2} \left( 4 - \frac{1}{3}\rho \right) \rho e^{-\rho/6}$$

Only  $R_{nl}(r)$  with  $l = 0$  has  $R_{nl}(0) \neq 0$

## Hydrogen Levels

Review : Radial wavefunction  $R_{nl}(r)$  of the hydrogenic atom

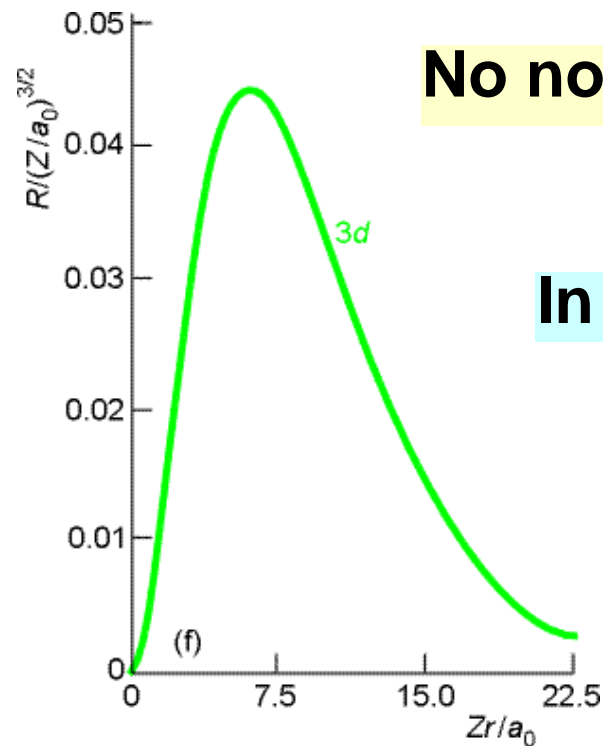

No nodes.  $R_{3,0}(r)$  everywhere positive

In general number of nodes  $n - l - 1$

$$R_{3,2}(r) = \frac{1}{81\sqrt{30}} \left( \frac{Z}{a_0} \right)^{3/2} \rho^2 e^{-\rho/6}$$

Only  $R_{nl}(r)$  with  $l = 0$  has  $R_{nl}(0) \neq 0$

## Orbitals of Hydrogenic Atom..PE vz. KE.

The balance of kinetic and potential energies that accounts for the structure of the ground state of hydrogen (and similar atoms).

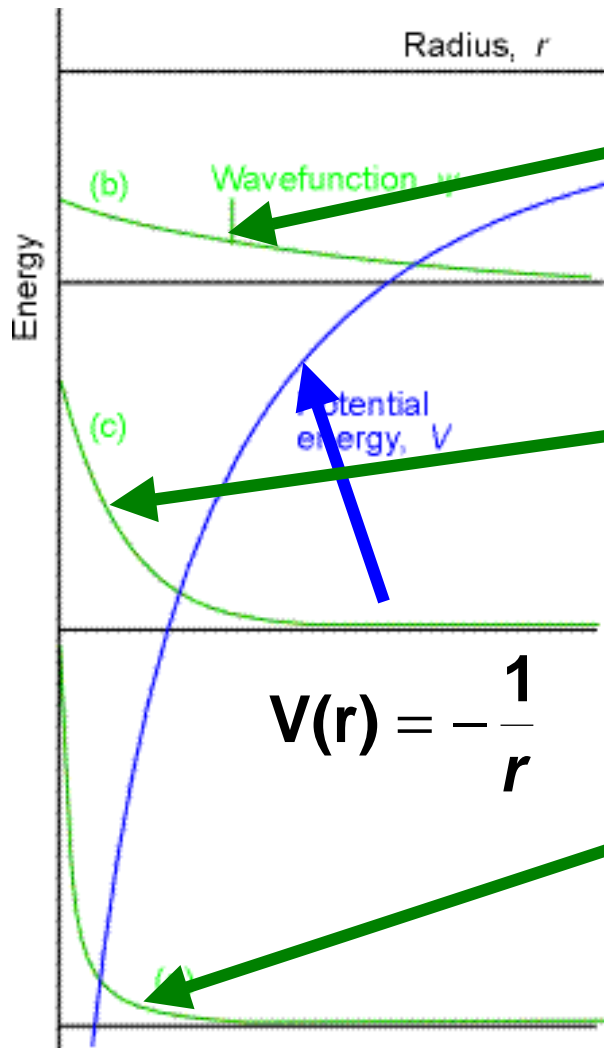

(b) the mean kinetic energy is low, but the potential energy is not very favourable;

; (c) the compromise of moderate kinetic energy and moderately favourable potential energy.

(a) The sharply curved but localized orbital has high mean kinetic energy, but low mean potential energy

# Hydrogen Levels

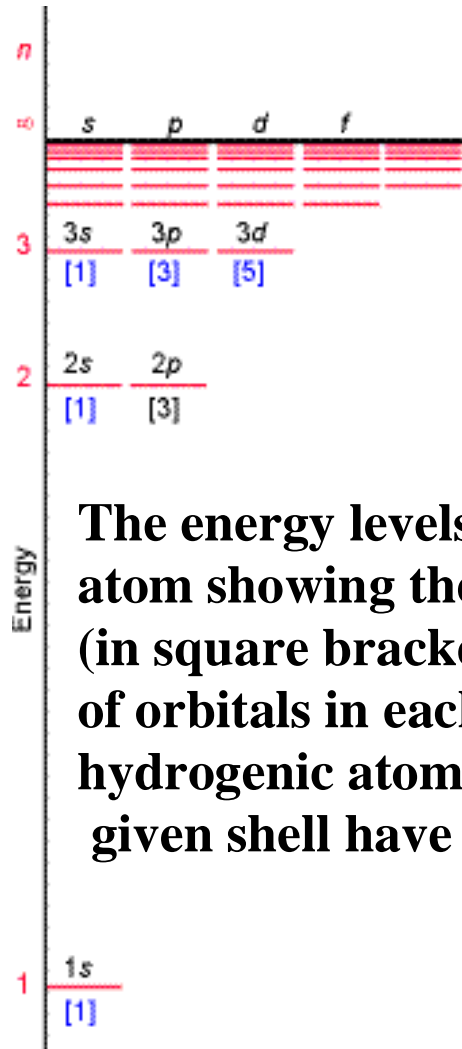

The energy levels of the hydrogen atom showing the subshells and (in square brackets) the numbers of orbitals in each subshell. In hydrogenic atoms, all orbitals of a given shell have the same energy.

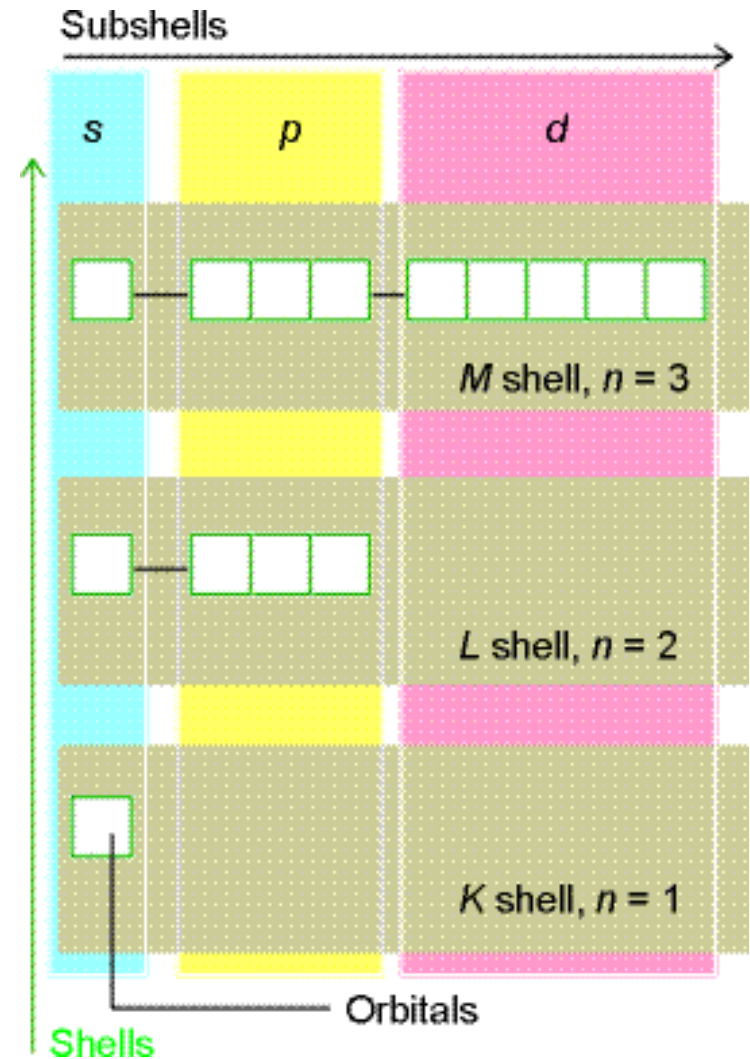

$$E = - \frac{z^2 \mu e^4}{32 \pi^2 \epsilon_0^2 \hbar^2 n^2}$$

the organization of orbitals into subshells characterized by  $l$  and shells characterized by  $n$ ).

$$n = 1, 2, 3, 4, \dots$$

$$l = 0, 1, 2, 3, \dots, n-1$$

$$m_l = 1, 1-1, 1-2, \dots, -1$$

## Hydrogen Levels

The energy is related to  $n$  by

$$E_n = \frac{hc\mathcal{R}_Z}{n^2} \quad hc\mathcal{R}_Z = \frac{Z^2\mu_Z e^4}{32\pi^2\epsilon_0^2\hbar^2}$$

$$\mu_Z = \frac{m_e M_Z}{m_e + M_Z}$$

The reduced mass

For the hydrogen atom with  $Z = 1$

$$E_n = \frac{hc\mathcal{R}_H}{n^2}$$

$$hc\mathcal{R}_H = \frac{\mu_H e^4}{32\pi^2\epsilon_0^2\hbar^2}$$

Introducing the Rydberg constant  $\mathcal{R}$

$$\mathcal{R} = \frac{m_e e^4}{32\pi^2\epsilon_0^2 h^3 c} \quad \text{we have} \quad \mathcal{R}_H = \frac{\mu_H}{m_e} \mathcal{R}$$

# Hydrogen Levels

Special feature on measuring the ionization potential of the hydrogen atom from its Lyman emission spectrum

Ionization energy  $I = hc\mathcal{R}$   
Energy required to remove electron from groundstate  
 $H \rightarrow H^+ + e^- - I$

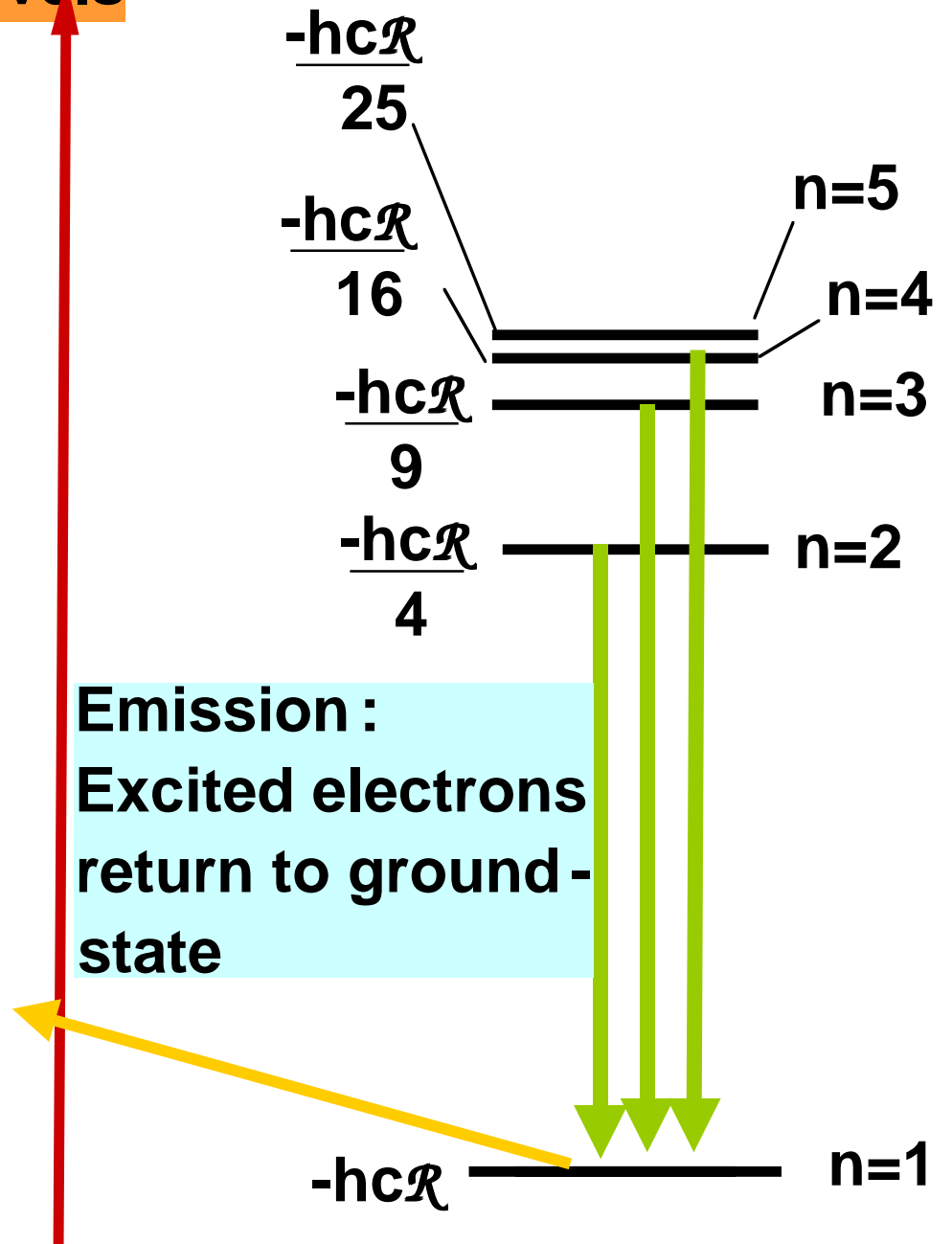

# Hydrogen Levels

Energy of widely separated stationary electron and nucleus

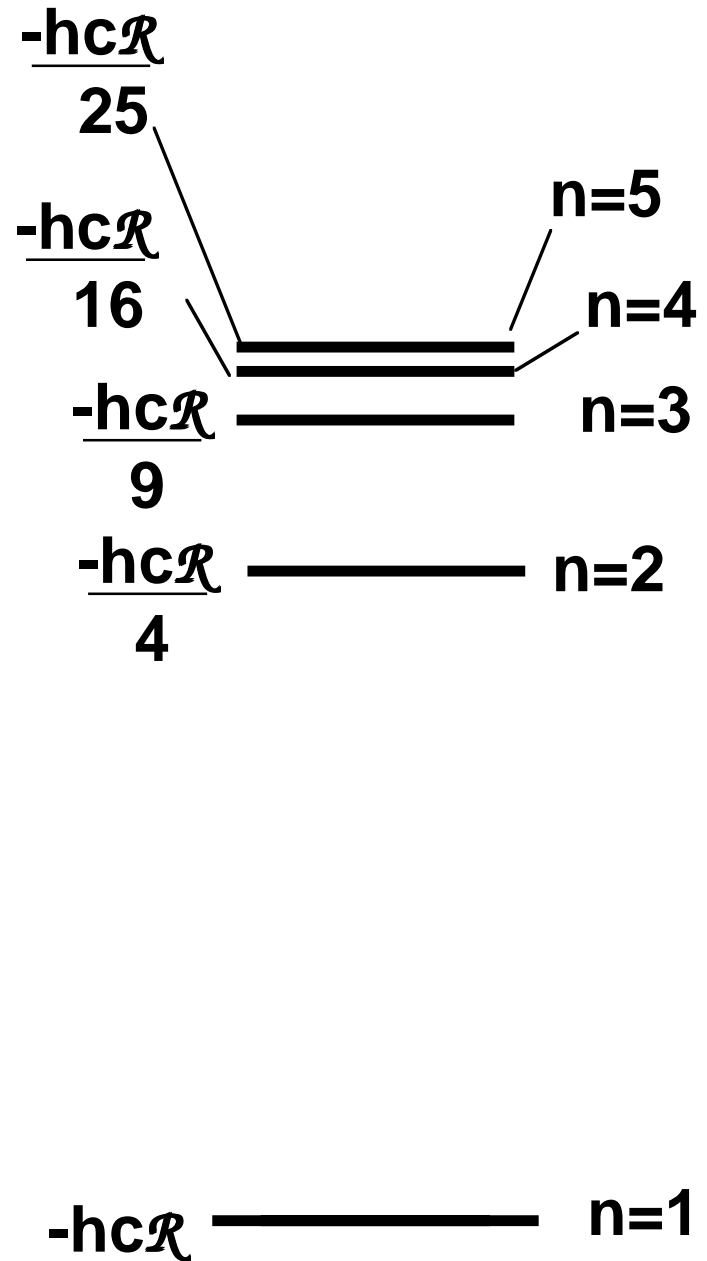
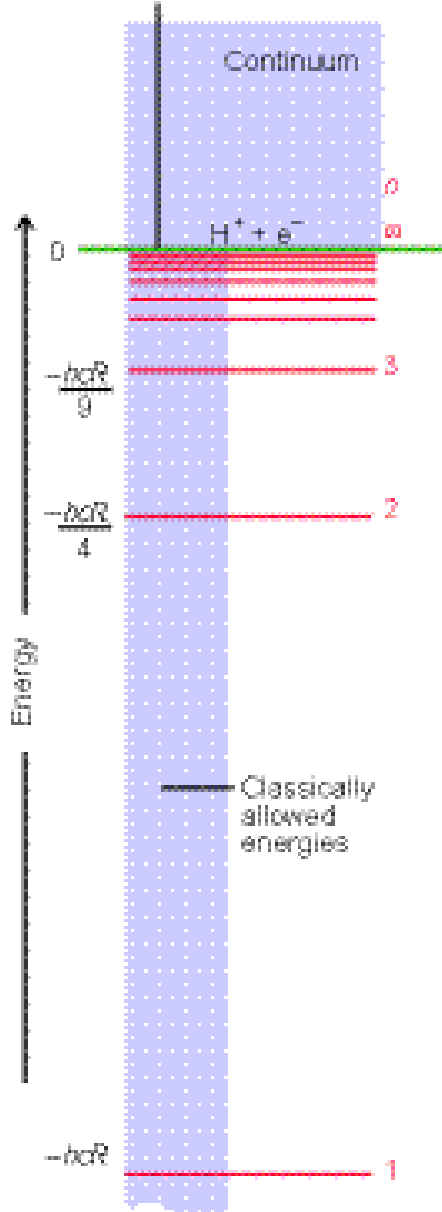

# Hydrogen Levels

Energy changes  $\Delta E(n \rightarrow 1)$  due to emission to groundstate

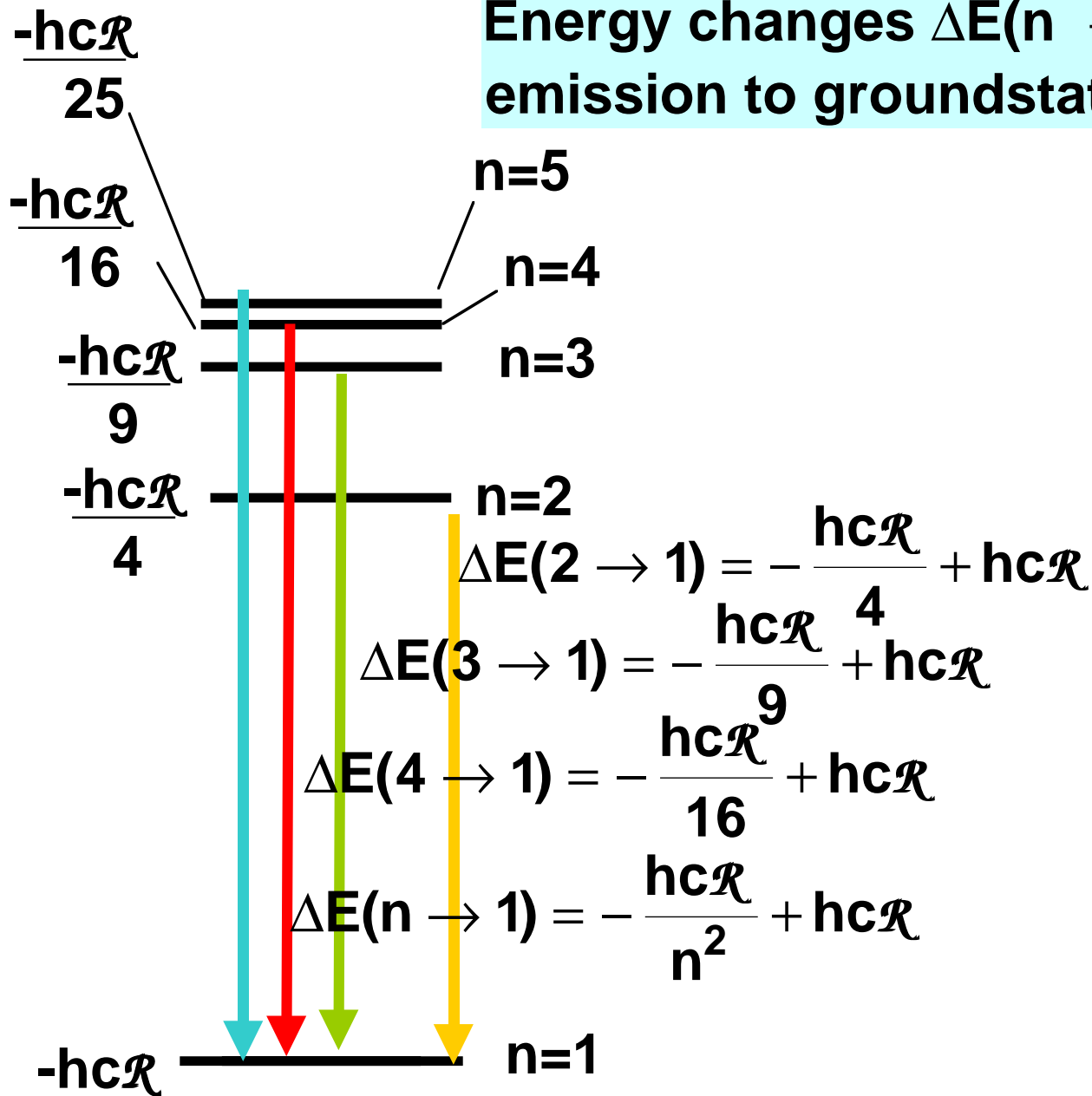

# Hydrogen Levels

Frequency of light  $\nu(n \rightarrow 1)$  due to emission to groundstate

Energy of light  $h\nu(n \rightarrow 1)$  due to emission to groundstate

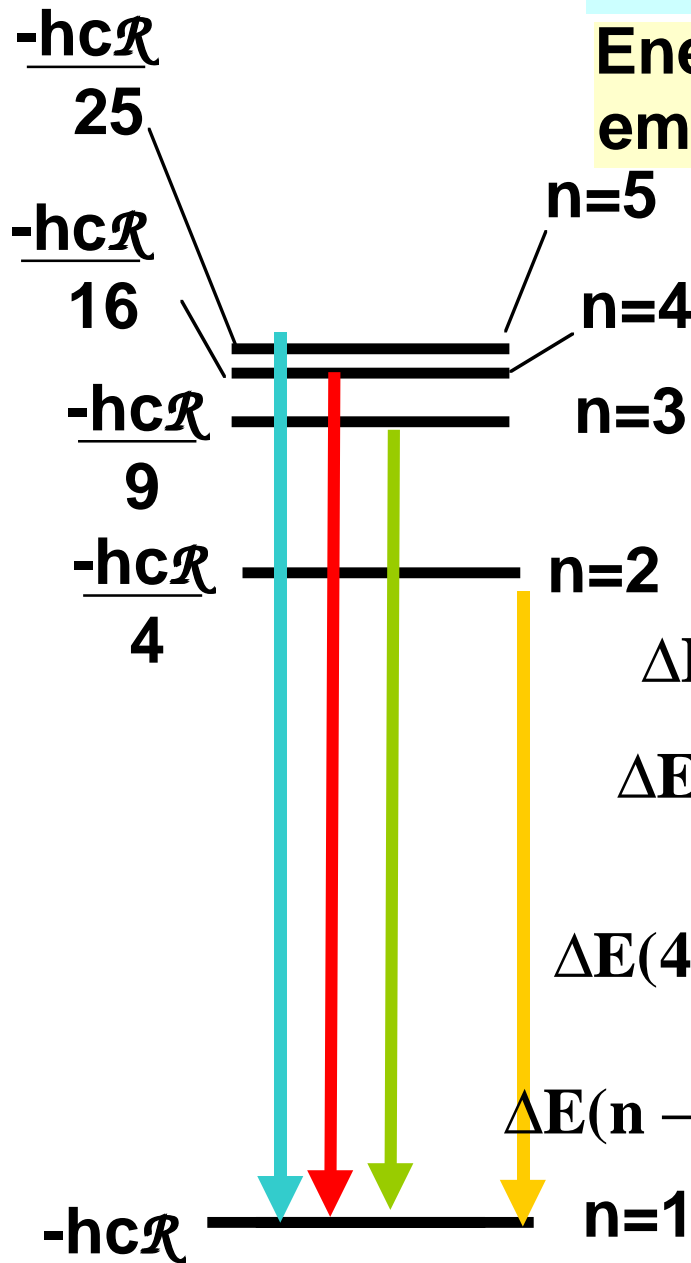

$$\Delta E(2 \rightarrow 1) = -\frac{hc\mathcal{R}}{4} + hc\mathcal{R} = h\nu(2 \rightarrow 1)$$

$$\Delta E(3 \rightarrow 1) = -\frac{hc\mathcal{R}}{9} + hc\mathcal{R} = h\nu(3 \rightarrow 1)$$

$$\Delta E(4 \rightarrow 1) = -\frac{hc\mathcal{R}}{16} + hc\mathcal{R} = h\nu(4 \rightarrow 1)$$

$$\Delta E(n \rightarrow 1) = -\frac{hc\mathcal{R}}{n^2} + hc\mathcal{R} = h\nu(n \rightarrow 1)$$

# Hydrogen Levels

Energy of light  $h\nu(n \rightarrow 1)$  due to emission to groundstate

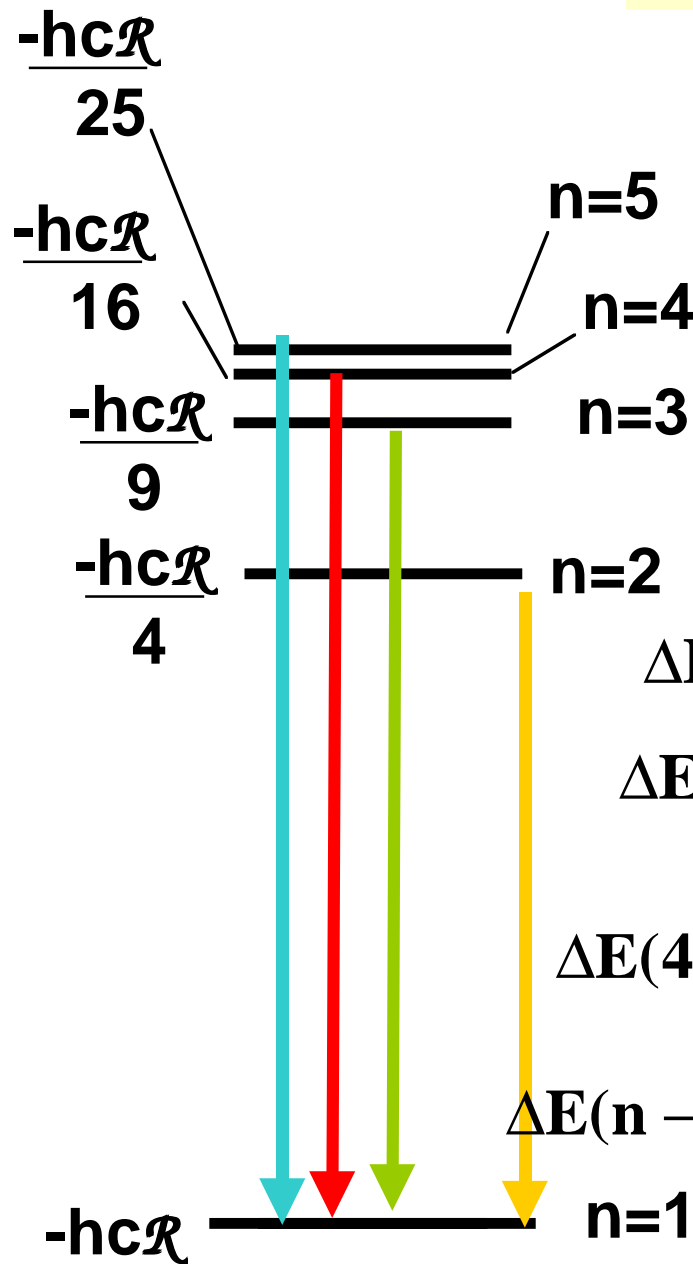

Also  $\nu(n \rightarrow 1)\lambda(n \rightarrow 1) = c$   
 or  
 $\nu(n \rightarrow 1) = c/\lambda(n \rightarrow 1) = c\tilde{\nu}(n \rightarrow 1)$   
 where  
 $1/\lambda(n \rightarrow 1) = \tilde{\nu}(n \rightarrow 1)$   
 Thus  
 $h\nu(n \rightarrow 1) = hc\tilde{\nu}(n \rightarrow 1)$

$$\Delta E(2 \rightarrow 1) = -\frac{hc\mathcal{R}}{4} + hc\mathcal{R} = hc\tilde{\nu}(2 \rightarrow 1)$$

$$\Delta E(3 \rightarrow 1) = -\frac{hc\mathcal{R}}{9} + hc\mathcal{R} = hc\tilde{\nu}(3 \rightarrow 1)$$

$$\Delta E(4 \rightarrow 1) = -\frac{hc\mathcal{R}}{16} + hc\mathcal{R} = hc\tilde{\nu}(4 \rightarrow 1)$$

$$\Delta E(n \rightarrow 1) = -\frac{hc\mathcal{R}}{n^2} + hc\mathcal{R} = hc\tilde{\nu}(n \rightarrow 1)$$

# Hydrogen Levels

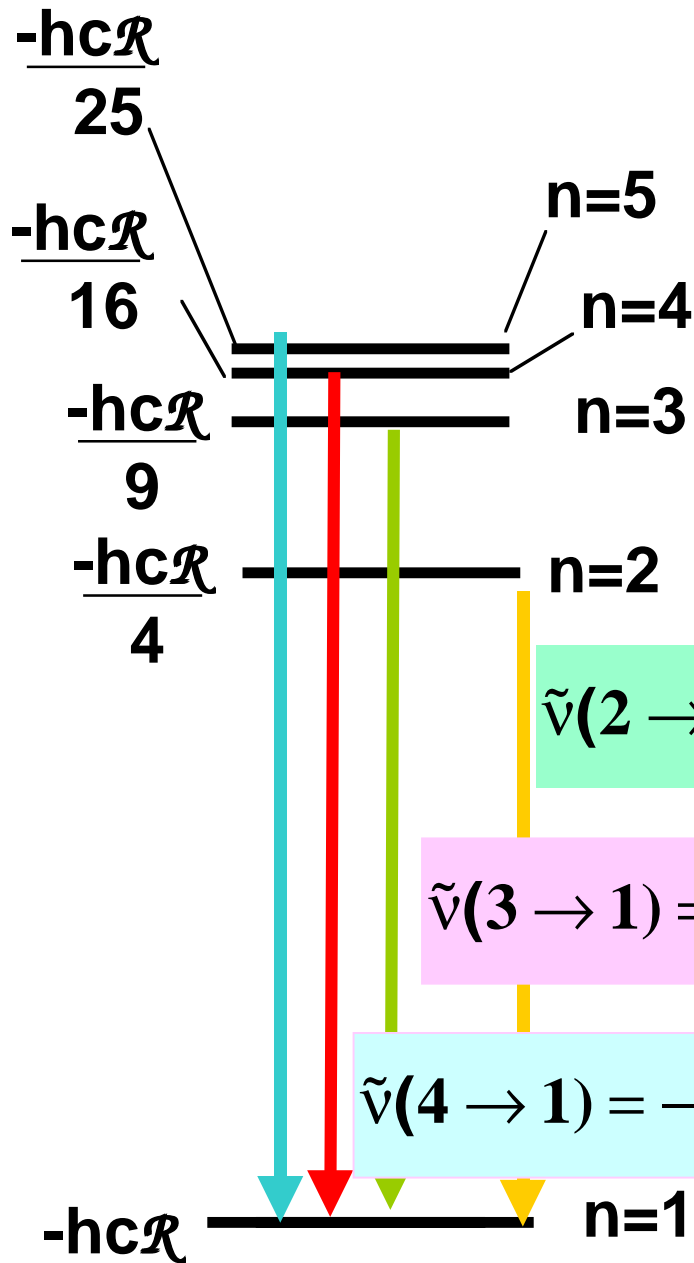

$$\Delta E(n \rightarrow 1) = -\frac{hc\mathcal{R}}{n^2} + hc\mathcal{R}$$

$$= hc\tilde{\nu}(n \rightarrow 1)$$

$$-\frac{hc\mathcal{R}}{n^2} + I = hc\tilde{\nu}(n \rightarrow 1)$$

$$\tilde{\nu}(n \rightarrow 1) = -\frac{\mathcal{R}}{n^2} + \frac{I}{hc}$$

$$\tilde{\nu}(2 \rightarrow 1) = -\frac{\mathcal{R}}{4} + \frac{I}{hc}$$

$$82\,250 \text{ cm}^{-1}$$

$$\tilde{\nu}(3 \rightarrow 1) = -\frac{\mathcal{R}}{9} + \frac{I}{hc}$$

$$97\,492 \text{ cm}^{-1}$$

$$\tilde{\nu}(4 \rightarrow 1) = -\frac{\mathcal{R}}{16} + \frac{I}{hc}$$

$$102\,824 \text{ cm}^{-1}$$

# Hydrogen Levels

Slope =  $-\mathcal{R}$

$$\tilde{\nu}(n \rightarrow 1) = -\frac{\mathcal{R}}{n^2} + \frac{I}{hc}$$

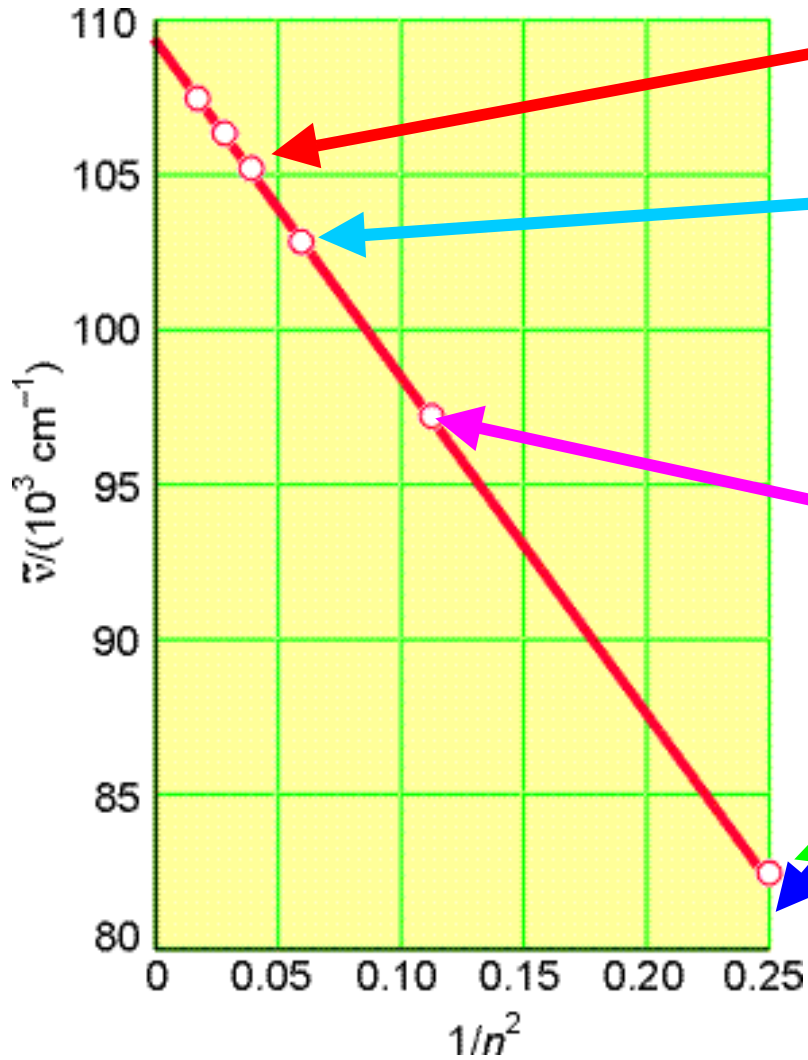

$$\tilde{\nu}(4 \rightarrow 1) = -\frac{\mathcal{R}}{16} + \frac{I}{hc}$$

102 824  $\text{cm}^{-1}$

$$\tilde{\nu}(3 \rightarrow 1) = -\frac{\mathcal{R}}{9} + \frac{I}{hc}$$

97 492  $\text{cm}^{-1}$

$$\tilde{\nu}(2 \rightarrow 1) = -\frac{\mathcal{R}}{4} + \frac{I}{hc}$$

82 250  $\text{cm}^{-1}$

Intercept =  $I/hc$

## What you need to know about the hydrogen atom from the previous lecture

1. You are not expected to be able to solve the Schrödinger equation for the hydrogen - like atom

$$\hat{H}\Psi_{n,l,m}(r, \varphi, \theta) = E_n \Psi_{n,l,m}(r, \varphi, \theta)$$

You should also be aware of the following commutation relations

$$[H, \hat{L}^2] = 0 \quad \text{and} \quad [H, \hat{L}_z] = 0$$

However you should be aware that the Hamiltonian can be written in the form

$$\bar{H} = -\frac{\hbar^2}{2\mu} \left[ \frac{\delta^2}{\delta^2 r} + \frac{2}{r} \frac{\delta}{\delta r} \right] + \frac{1}{2\mu r^2} L^2 - \frac{Ze}{4\pi\epsilon_0 r}$$

where  $r$  is the distance between the hydrogen - like atom and the electron whereas  $\mu$  is the reduced mass.

## What you need to know about the hydrogen atom from the previous lecture

2. You are not required to memorize the exact form of the eigenfunctions.

You should recognized that they can be written as a product of a radial part  $R_{nl}(r)$  and the spherical harmonics

$Y_{lm}(\varphi, \theta)$

[eigenfunctions of  $\hat{L}^2$  and  $\hat{L}_z$ ] as

$$\Psi_{n,l,m}(r, \varphi, \theta) = R_{nl}(r)Y_{lm}(\varphi, \theta)$$

with the corresponding energies given by

$$E = -\frac{Z^2 m e^4}{32 p^2 e_0^2 \hbar^2 n^2}$$

It is important that you remember the possible quantum numbers for  $l$  and  $m$  with respect to a given  $n$ .

## **What you need to know about the hydrogen atom from this lecture**

**3. You should be able to count the number of nodes in  $R_{n,l}(r)$  as  $n - l - 1$  and realize that  $R_{n,l}(r)$  only is different from zero at the nucleus for  $l = 0$ .**

**4. You are expected to relate the  $l$  and  $m$  quantum numbers to the length of the orbital angular momentum vector and the projection of the orbital angular momentum vector on the arbitrary  $z$  - axis, respectively.**

**5. Review the way in which absorption spectra, emission spectra and ionization potentials for the hydrogen atom are derived from the energy levels  $E_n$  and make note of the degeneracy of the energy levels  $E_n$  (subshell structure)**